

## Flexible probes for AC current

AmpFlex® series



### SERIE AmpFlex®

These flexible current probes are as at home measuring low AC currents of a few tens mA as they are measuring high currents of several tens of kA. Their main point of interest is their flexibility and the ease with which electrical conductors of all shapes and sizes (cables, busbars) and degrees of accessibility can be gripped.

They have a number of other advantages; they are lightweight (no magnetic circuit), they do not suffer from the saturation effect and their high level of accuracy combined with minimal phase shift make them perfect for power measurement applications.

- **AmpFlex® A110 series:**

The sensors in the A110 Series have a flexible core connected by a shielded cable to a small unit containing processing electronics. This IP54 unit offers 4 measurement calibres and can be connected directly to any multimeter, wattmeter or logger. The length of the sensors in this Series (up to 120 cm as standard) enables you to clamp cables with a large cross-section or several conductors simultaneously. The A110 can be used for measurements up to 30 kA AC.

The AmpFlex® A110 offers IP67 ingress protection and can be connected to the AC voltage input (mV AC, V AC) of any multimeter or measuring instrument equipped with Ø 4 mm female banana plugs.

- **AmpFlex® A130:**

The A130 model is a version of the A110 Series adapted for measurements on three-phase installations. It is equipped with BNC connections. The processing unit offers 3 measurement calibres. The A130 sensor can be connected to the AC voltage inputs (mV AC, V AC) of any power analyser, logger or measuring instrument equipped with BNC plugs.

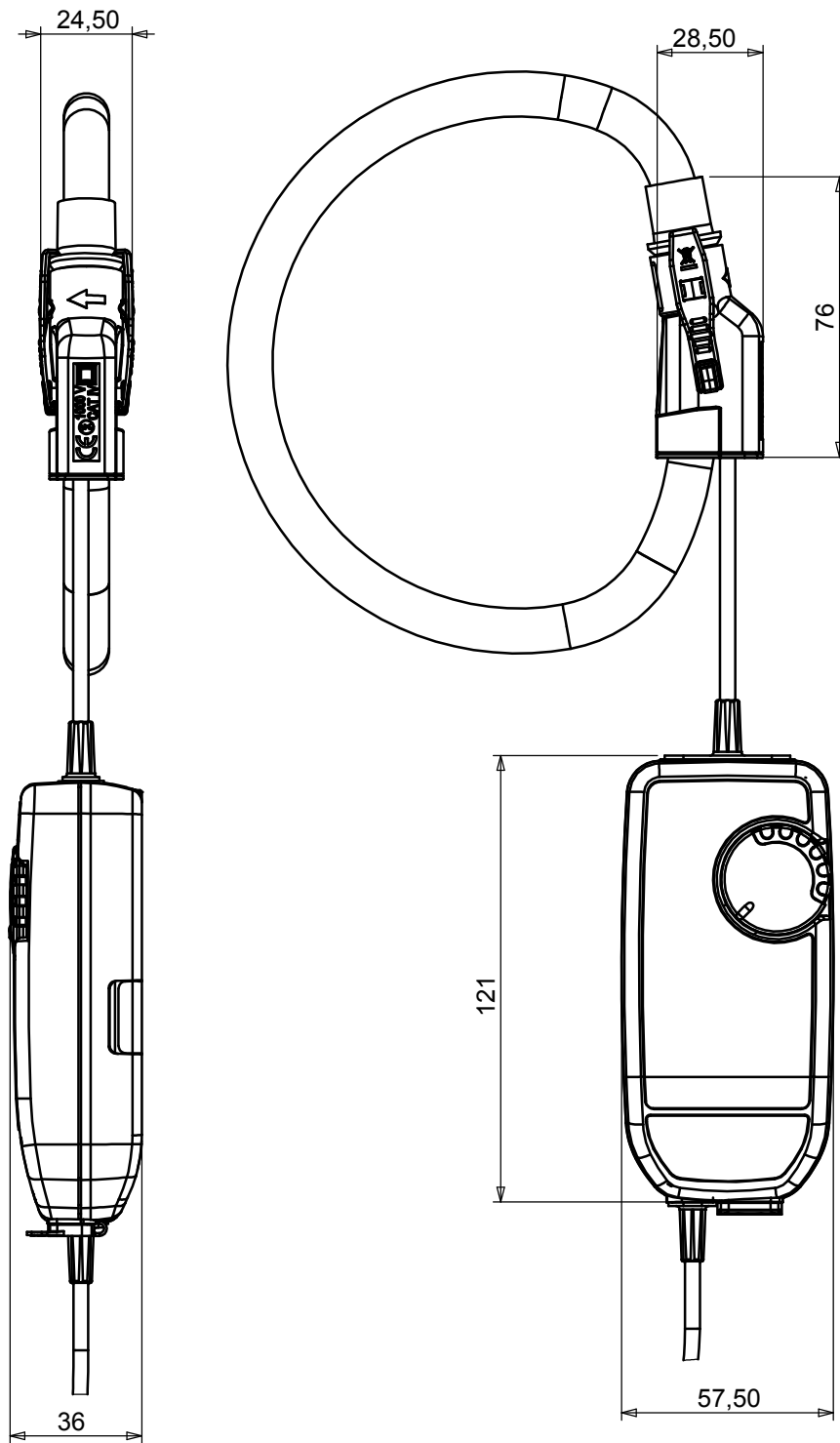

Current	3 A AC	30 A AC	300 A AC	3,000 A AC
Output	1 mV/mA	100 mV/A	10 mV/A	1 mV/A

## DESCRIPTION

The AmpFlex® A110 is a flexible sensor which comprises an active part (Rogowski coil) and a casing containing an electronic processing unit. Unlike current clamps using magnetic circuits, the AmpFlex® models are flexible sensors without magnetic saturation constraints. As a result, they offer excellent linearity, low phase shift, a large dynamic range for measurement (up to several kA) while remaining easy to use. The sensors' flexibility makes it easy to clamp the conductor, whatever its type (cable, busbar, strand, etc.) and access conditions.

The design of the click-together opening and closing system means it can be handled with protective gloves.

The AmpFlex® A110 can be connected to the AC voltage input (mV AC, V AC) of any multimeter or measuring instrument equipped with Ø 4 mm female banana plugs.

The AmpFlex® A110 can be powered by batteries or a standard external power supply. If the power supply fails, the instrument's batteries take over.

To maximize the battery life, the MiniFlex® A110 has an automatic standby system which can be deactivated at start-up to perform long-term measurement campaigns. The MiniFlex® A110 has 3 green, yellow and red LEDs indicating, respectively, the power supply status, the status of the automatic standby function and any overruns of the measurement capacity.



## SPECIFICATIONS FOR CURRENT MEASUREMENT <sup>(1)</sup>

Calibre ( $I_N$ )	3 A	30 A	300 A	3,000 A
Measurement range in use	0,08 .. 3 A AC	0.5 .. 30 A AC	0.5 .. 300 A AC	0.5 .. 3,000 A AC
Specified measurement range	0.5 .. 3 A AC	2 .. 30 A AC	5 .. 300 A AC	50 .. 3,000 A AC
Output/input ratio	1 V / A	100 mV / A	10 mV / A	1 mV / A
Bandwidth at -3 dB	10 Hz .. 10 kHz	10 Hz .. 20 kHz	10 Hz .. 20 kHz	10 Hz .. 20 kHz
Frequency limitation	Null	Null	Null	See curve XX
Intrinsic uncertainty	$\leq 1 \%$	$\leq 1 \%$	$\leq 1.5 \%$ ( $I < 10 \% I_N$ ) $\leq 1 \%$ ( $I \geq 10 \% I_N$ )	$\leq 1.5 \%$ ( $I < 10 \% I_N$ ) $\leq 1 \%$ ( $I \geq 10 \% I_N$ )
Phase shift at 50 Hz	$\leq 1^\circ$ (0.5° typical)	$\leq 1^\circ$ (0.5° typical)	$\leq 1^\circ$ (0.5° typical)	$\leq 1^\circ$ (0.5° typical)

## ELECTRICAL SPECIFICATIONS <sup>(1)</sup>

- Operating voltage:**  
1,000 V<sub>RMS</sub> (Cat. IV)
- Battery:**  
2 x 1.5 V batteries (NEDA 15A, IEC LR6, AA)  
+5 VDC with a type B micro-USB connector
- Battery life <sup>(2)</sup>:**  
300 hours typical  
1,800 10-minute approx. measurements
- Consumption:**  
10  $\mu$ A (position OFF)  
90  $\mu$ A (sleep mode)
- Battery level indication:**  
Flashing green LED (batteries voltage > 2 V)
- Influence of battery voltage:**  
 $\leq 0.1 \%$  (0.02 % typical) from 3.1 V to 2 V
- Influence of temperature:**  
 $\leq 0.5 \%$  (0.15 % typical) of output signal per 10 °K
- Influence of relative humidity:**  
 $\leq 0.5 \%$  (0.2 % typical) of output signal
- Influence of conductor position in the sensor <sup>(3)</sup>:**  
 $\leq 2.5 \%$  (1 % typical)
- Influence of sensor deformation <sup>(4)</sup>:**  
 $\leq 1 \%$  (0.2 % typical)
- Influence of adjacent conductor <sup>(5)</sup>:**  
 $\leq I_{ADJ} \times 1 \%$  (2 % near click-lock system)  
(0.2 % typical)
- Input impedance of the measuring instrument:**  
 $\geq 1 \text{ M}\Omega$
- Common mode rejection <sup>(6)</sup>:**  
 $\leq 80 \text{ dB}$  (100 dB typical)
- Influence of the measurement instrument's impedance Z:**  
 $\leq 0.1 \%$  at 10 k $\Omega$

## MECHANICAL SPECIFICATIONS

- **Clamping capacity:**  
Model 45 cm: Ø max 7 cm  
Model 80 cm: Ø max 12.5 cm
- **Bending radius:**  
≥ 40 mm
- **Operating temperature:**  
-10 °C to +55 °C
- **Storage temperature:**  
-40 °C to +70 °C
- **Max temperature of measured cable:**  
90 °C for 10 minutes max.
- **Relative humidity for operation:**  
0 to 85 % RH decreasing linearly above 35 °C
- **Operating altitude:**  
0 to 2,000 m
- **Casing protection rating (leakproofing):**  
Casing: IP54  
Flexible sensor: IP 67  
According to IEC 60529 Ed. 2.2-2013

- **Drop test:**  
1 m
- **Self-extinguishing capability:**  
Casing: UL94-V2  
Sensor: UL94 V0
- **Dimensions:**  
Casing: 120 x 55 x 39 (overall)  
Connector lead: 2 m (connects sensor to casing)  
Length of output cable: 0.5 m  
Ø of sensor: 12 mm  
Connection cable Ø: 4 mm
- **Weight:**  
Model 45 mm: 450 g  
Sensor: 30 g / 10 cm
- **Colours:**  
Sensor: red  
Click-lock system: dark grey  
Casing: dark grey
- **Output:**  
Two-wire cable with reinforced or double isolation terminated by 2 red and black Ø 4 mm isolated male banana plugs

## SAFETY SPECIFICATIONS

- **Electrical safety:**  
Class II equipment with double or reinforced insulation between the primary and the secondary (winding connected to the connection cable) as per EN 61010-1 and 61010-2-032 Ed. 03-2012:  
Sensor:  
- Type B  
- 1,000 V Cat. IV pollution degree 2  
Casing:  
- 600 V Cat. III between the terminals and the external enclosure of the casing
- **Electromagnetic compatibility (EMC):**  
Complies with the industrial environments according to EN 61326-1 Ed. 02-2012:  
- Immunity to radiated fields: at 3 V/m, error ≤ 5 % of measurement range (criterion A)

(1) Conditions of reference: 23 °C ± 5 °K, 20 % to 75 % RH

Battery voltage 3.2 V ± 0.1 VDC

Frequency and form of signal measured: 30 to 440 Hz sinusoidal

Continuous magnetic field < 40 A/m

Absence of external AC magnetic field

Absence of external electrical field

Measured conductor centred in the circular sensor (coil) after operation for 1 minute

Measurement instrument input impedance ≥ 1 MΩ

(2) With 3,000 mA/h batteries, for a supplied voltage between 3.2 V and 1.8 V (1.6 V to 0.9 V per battery), giving an average voltage of 2.8 V

(3) Whatever the conductor's position within the loop, as long as the sensor is not distorted (circular sensor)

(4) Oblong shape

(5) Adjacent conductor carrying an AC current  $I_{adj}$ , in contact with the sensor

(6) For a 600 V voltage applied between the enclosure and the secondary

### 3,000 A calibre

Limitation of current measured according to frequency

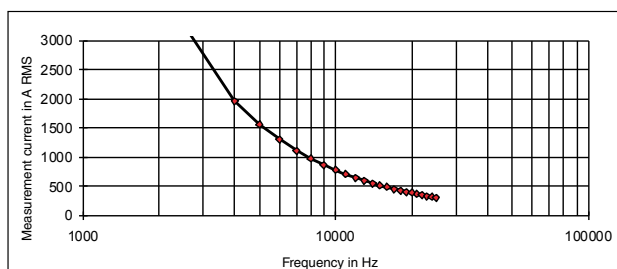

To order	Reference
AmpFlex® <b>A110</b> <b>3-30-300-3,000 A / 3 V</b> , length <b>45 cm</b> Output via cable terminated by 2 x Ø 4 mm isolated male banana plugs	P01120630
AmpFlex® <b>A110</b> <b>3-30-300-3,000 A / 3 V</b> , length <b>80 cm</b> Output via cable terminated by 2 x Ø 4 mm isolated male banana plugs	P01120631

## FREQUENCY RESPONSE

### Calibre 3 A

Typical error on measurement according to frequency for a current of 2 A

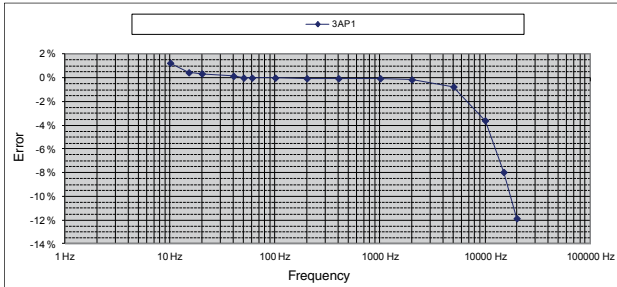

Typical phase shift according to frequency for a current of 2 A

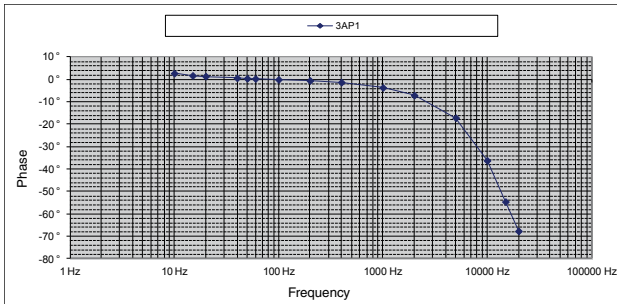

### 30 A calibre

Typical error on measurement according to frequency for a current of 20 A

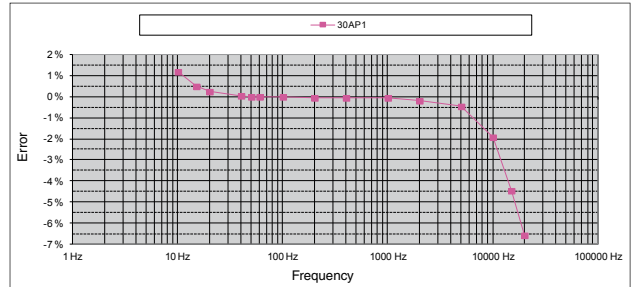

Typical phase shift according to frequency for a current of 20 A

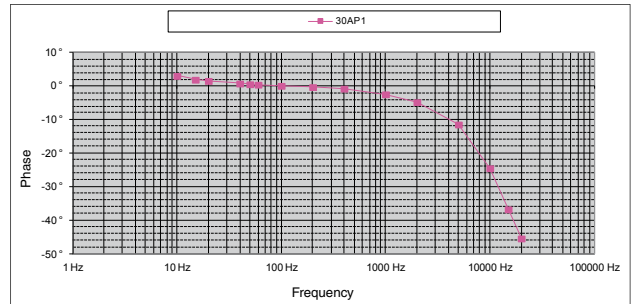

### 300 A calibre

Typical error on measurement according to frequency for a current of 20 A

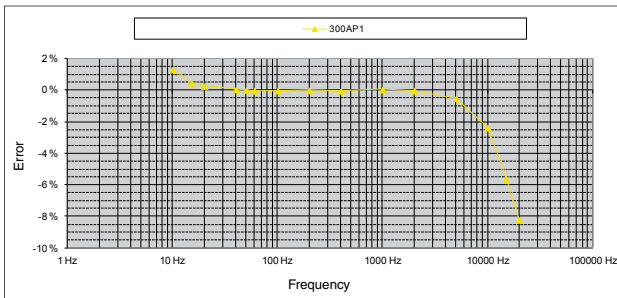

Typical phase shift according to frequency for a current of 20 A

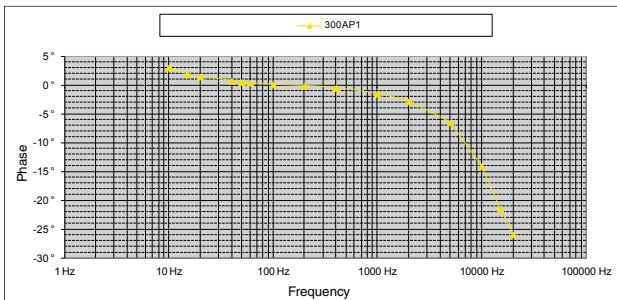

### 3,000 A calibre

Typical error on measurement according to frequency for a current of 20 A

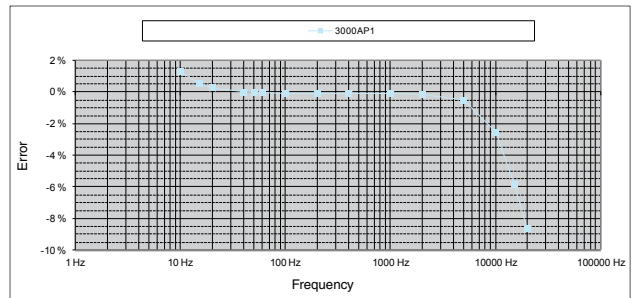

Typical phase shift according to frequency for a current of 20 A

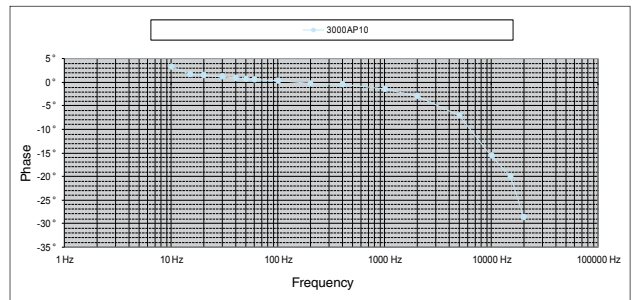

<b>Current</b>	30 A AC	300 A AC	3,000 A AC	30,000 A AC
<b>Output</b>	100 mV/A	10 mV/A	1 mV/A	0.1 mV/A

## DESCRIPTION

The AmpFlex® A110 is a flexible sensor which comprises an active part (Rogowski coil) and a casing containing an electronic processing unit. Unlike current clamps using magnetic circuits, the AmpFlex® models are flexible sensors without magnetic saturation constraints. As a result, they offer excellent linearity, low phase shift, a large dynamic range for measurement (up to several kA) while remaining easy to use. The sensors' flexibility makes it easy to clamp the conductor, whatever its type (cable, busbar, strand, etc.) and access conditions.

The design of the click-together opening and closing system means it can be handled with protective gloves.

The AmpFlex® A110 can be connected to the AC voltage input (mV AC, V AC) of any multimeter or measuring instrument equipped with Ø 4 mm female banana plugs.

The AmpFlex® A110 can be powered by batteries or a standard external power supply. If the power supply fails, the instrument's batteries take over.

To maximize the battery life, the MiniFlex® A110 has an automatic standby system which can be deactivated at start-up to perform long-term measurement campaigns.

The MiniFlex® A110 has 3 green, yellow and red LEDs indicating, respectively, the power supply status, the status of the automatic standby function and any overruns of the measurement capacity.



## SPECIFICATIONS FOR CURRENT MEASUREMENT <sup>(1)</sup>

Calibre ( $I_N$ )	30 A	300 A	3,000 A	30,000 A
Measurement range in use	0.5 .. 30 A AC	0.5 .. 300 A AC	0.5 .. 3,000 A AC	0.5 .. 30,000 A AC
Specified measurement range	0.5 .. 30 A AC	10 .. 300 A AC	10 .. 3,000 A AC	50 .. 30,000 A AC
Output/input ratio	100 mV / A	10 mV / A	1 mV / A	0.1 mV / A
Bandwidth at -3 dB	10 Hz .. 10 kHz	10 Hz .. 10 kHz	10 Hz .. 20 kHz	10 Hz .. 20 kHz
Frequency limitation	Null	Null	Null	See curve
Intrinsic uncertainty	≤ 1 %	≤ 1 %	≤ 1.5 % ( $I < 10 \% I_N$ ) ≤ 1 % ( $I \geq 10 \% I_N$ )	≤ 1.5 % ( $I < 10 \% I_N$ ) ≤ 1 % ( $I \geq 10 \% I_N$ )
Phase shift at 50 Hz	≤ 1° (0.5° typical)	≤ 1° (0.5° typical)	≤ 1° (0.5° typical)	≤ 1° (0.5° typical)

## ELECTRICAL SPECIFICATIONS <sup>(1)</sup>

- Operating voltage:**  
1,000 V<sub>RMS</sub> (Cat. IV)
- Battery:**  
Two 1.5 V batteries (NEDA 15A, IEC LR6, AA)  
+5 VDC with a type B micro-USB connector
- Battery life <sup>(2)</sup>:**  
300 hours typical  
1,800 10-minute approx. measurements
- Consumption:**  
10 µA (position OFF)  
90 µA (sleep mode)
- Battery level indication:**  
Flashing green LED (batteries voltage > 2 V)
- Influence of battery voltage:**  
≤ 0.1 % (0.02 % typical) from 3.1 V to 2 V
- Influence of temperature:**  
≤ 0.5 % (0.15 % typical) of output signal per 10 °K
- Influence of relative humidity:**  
≤ 0.5 % (0.2 % typical) of output signal
- Influence of conductor position in the sensor <sup>(3)</sup>:**  
≤ 2.5 % (1 % typical)
- Influence of sensor deformation <sup>(4)</sup>:**  
≤ 1 % (0.2 % typical)
- Influence of adjacent conductor <sup>(5)</sup>:**  
≤  $I_{ADJ} \times 1 \%$  (2 % near click-lock system)  
(0.2 % typical)
- Input impedance of the measuring instrument:**  
≥ 1 MΩ
- Common mode rejection <sup>(6)</sup>:**  
≤ 80 dB (100 dB typical)
- Influence of the measurement instrument's impedance Z:**  
≤ 0.1 % at 10 kΩ

## MECHANICAL SPECIFICATIONS

- **Clamping capacity:**  
Model 120 mm: Ø max 19 cm
- **Bending radius:**  
≥ 40 mm
- **Operating temperature:**  
-10 °C to +55 °C
- **Storage temperature:**  
-40 °C to +70 °C
- **Max temperature of measured cable:**  
90 °C for 10 minutes max.
- **Relative humidity for operation:**  
0 to 85 % RH decreasing linearly above 35 °C
- **Operating altitude:**  
0 to 2,000 m
- **Casing protection rating (leakproofing):**  
Casing: IP54  
Flexible sensor: IP 67  
According to IEC 60529 Ed. 2.2-2013
- **Drop test:**  
1 m

- **Self-extinguishing capability:**  
Casing: UL94-V2  
Sensor: UL94 V0
- **Dimensions:**  
Casing: 120 x 55 x 39 (overall)  
Connector lead: 2 m (connects sensor to casing)  
Length of output cable: 0.5 m  
Ø of sensor: 12 mm  
Connection cable Ø: 4 mm
- **Weight:**  
Model 45 mm: 450 g  
Sensor: 30 g / 10 cm
- **Colours:**  
Sensor: red  
Click-lock system: dark grey  
Casing: dark grey
- **Output:**  
Two-wire cable with reinforced or double isolation terminated by 2 red and black Ø 4 mm isolated male banana plugs

## SAFETY SPECIFICATIONS

- **Electrical safety:**  
Class II equipment with double or reinforced insulation between the primary and the secondary (winding connected to the connection cable) as per EN 61010-1 and 61010-2-032 Ed. 03-2012:  
Sensor:  
- Type B  
- 1,000 V Cat. IV pollution degree 2  
Casing:  
- 600 V Cat. III between the terminals and the external enclosure of the casing
- **Electromagnetic compatibility (EMC):**  
Complies with the industrial environments according to EN 61326-1 Ed. 02-2012:  
- Immunity to radiated fields: at 3 V/m, error ≤ 5 % of measurement range (criterion A)

- (1) Conditions of reference: 23 °C ± 5 °K, 20 % to 75 % RH  
Battery voltage 3.2 V ± 0.1 VDC  
Frequency and form of signal measured: 30 to 440 Hz sinusoidal  
Continuous magnetic field < 40 A/m  
Absence of external AC magnetic field  
Absence of external electrical field  
Measured conductor centred in the circular sensor (coil) after operation for 1 minute  
Measurement instrument input impedance ≥ 1 MΩ
- (2) With 3,000 mA/h batteries, for a supplied voltage between 3.2 V and 1.8 V (1.6 V to 0.9 V per battery), giving an average voltage of 2.8 V
- (3) Whatever the conductor's position within the loop, as long as the sensor is not distorted (circular sensor)
- (4) Oblong shape
- (5) Adjacent conductor carrying an AC current  $I_{adj}$ , in contact with the sensor
- (6) For a 600 V voltage applied between the enclosure and the secondary

### 3,000 A calibre

Limitation of current measured according to frequency

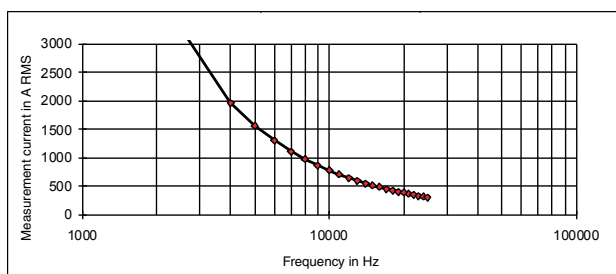

### 30,000 A calibre

Limitation of current measured according to frequency

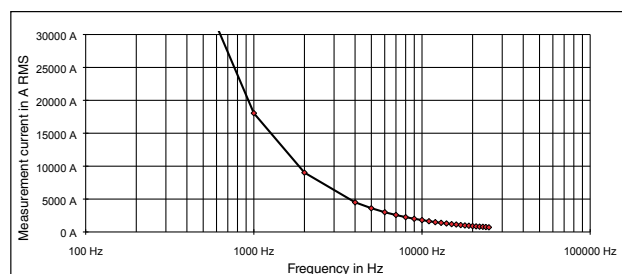

To order	Reference
AmpFlex® <b>A110</b> <b>30-300-3k-30k A / 3 V</b> , length <b>120 cm</b> Output via cable terminated by 2 x Ø 4 mm isolated male banana plugs	P01120632

## FREQUENCY RESPONSE

### 30 A calibre

Typical error on measurement according to frequency for a current of 2 A

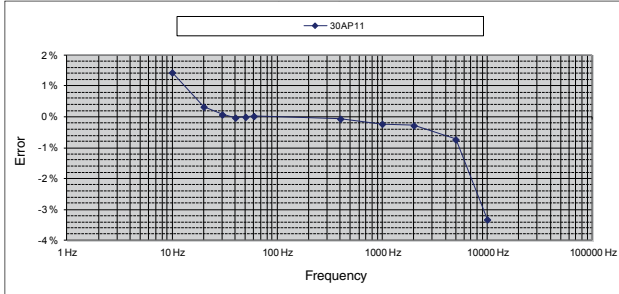

### 300 A calibre

Typical error on measurement according to frequency for a current of 20 A

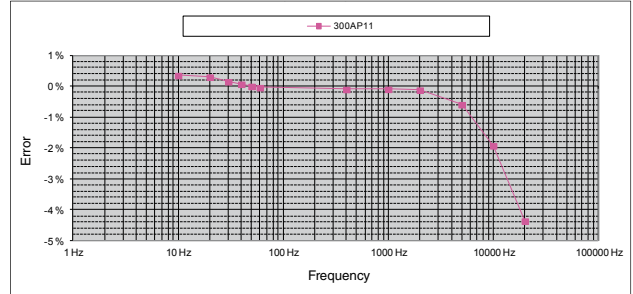

Typical phase shift according to frequency for a current of 20 A

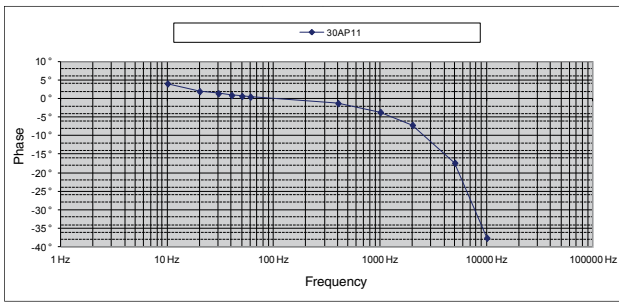

Typical phase shift according to frequency for a current of 20 A

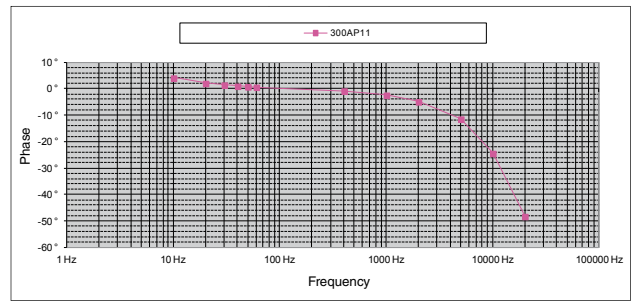

### 3,000 A calibre

Typical error on measurement according to frequency for a current of 20 A

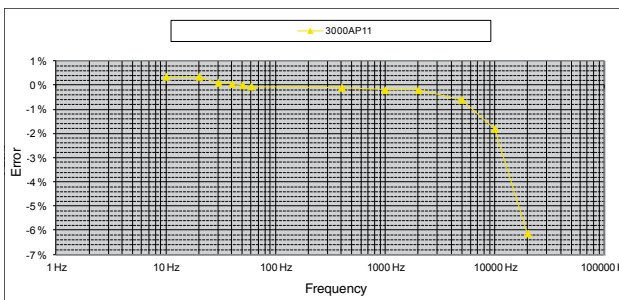

### 30,000 A calibre

Typical error on measurement according to frequency for a current of 20 A

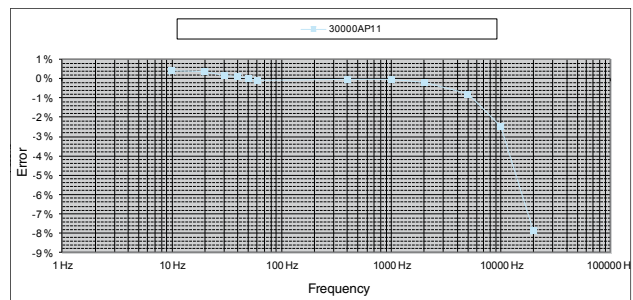

Typical phase shift according to frequency for a current of 20 A

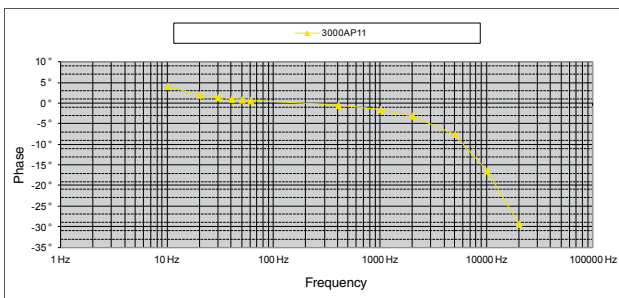

Typical phase shift according to frequency for a current of 20 A

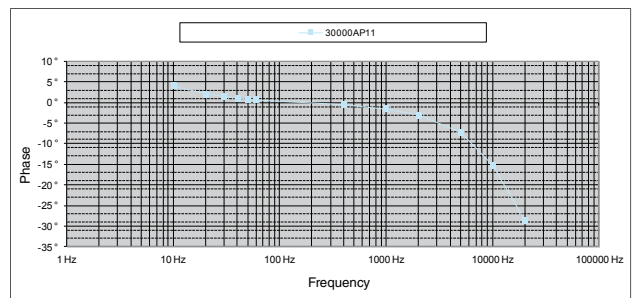



## CONFIGURATIONS

Level 1

A	1	1	0																
---	---	---	---	--	--	--	--	--	--	--	--	--	--	--	--	--	--	--	--

### 1 Category

### 2 Lead length in centimeters

Min value : **050** (50 cm)  
 Max value : **995** (9.95 m)

Increment per 5 cm section

### 3 Length of connection lead in centimeters

Min value : **050** (50 cm)  
 Max value : **995** (9.95 m)

Increment per 5 cm section

### 4 Output via

- A:** coaxial cable of the length to be defined in 5 terminated by a 600 V CAT III isolated male BNC socket
- B:** cable 50 cm long terminated by 2 red/black Ø 4 mm isolated male banana plugs rated 600 V CAT IV
- C:** shielded cable with 2 bared, tin-plated conductors of the length to be defined in 5, rated 600 V CAT IV

### 5 Output cable length in cm

If 4 = "A"

Min value : **050** (50 cm)  
 Max value : **110** (1.10 m)

Increment per 5 cm section

If 4 = "C"

Min value : **050** (50 cm)  
 Max value : **995** (9.95 m)

Increment per 5 cm section

### 6 Measurement calibres (sensitivities)

- A:** 3 A-30 A-300 A -3000 A/3 V (1 V-100 mV-10 mV-1 mV/A)
- B:** 30 A-300 A -3,000 A-30,000 A / 3 V (100 mV-10 mV-1 mV-0.1 mV / A)

A	1	1	0
---	---	---	---

..	..	..
----	----	----

On request - Modulo 5 cm  
 Coding over 3 characters  
 E.g. 50 cm = 050; 9 m = 900

..	..	..
----	----	----

On request - Modulo 5 cm  
 Coding over 3 characters  
 E.g. 50 cm = 050; 9 m = 900

..
----

..	..	..
----	----	----

On request - Modulo 5 cm  
 Coding over 3 characters  
 E.g. 50 cm = 050; 1 m = 100

..
----

Reference: (products available in stock)	Codes															
<table border="1"> <tr> <td>A</td><td>1</td><td>1</td><td>0</td><td>0</td><td>8</td><td>0</td><td>2</td><td>0</td><td>0</td><td>B</td><td>0</td><td>5</td><td>0</td><td>A</td> </tr> </table>	A	1	1	0	0	8	0	2	0	0	B	0	5	0	A	P01120631
A	1	1	0	0	8	0	2	0	0	B	0	5	0	A		
<table border="1"> <tr> <td>A</td><td>1</td><td>1</td><td>0</td><td>1</td><td>2</td><td>0</td><td>2</td><td>0</td><td>0</td><td>B</td><td>0</td><td>5</td><td>0</td><td>B</td> </tr> </table>	A	1	1	0	1	2	0	2	0	0	B	0	5	0	B	P01120631
A	1	1	0	1	2	0	2	0	0	B	0	5	0	B		

<b>Current</b>	30 A AC	300 A AC	3,000 A AC
<b>Output</b>	100 mV/A	10 mV/A	1 mV/A

## DESCRIPTION

The AmpFlex® A130 is a flexible sensor which comprises an active part (Rogowski coil) and a casing containing an electronic processing unit. Unlike current clamps using magnetic circuits, the AmpFlex® models are flexible sensors without magnetic saturation constraints. As a result, they offer excellent linearity, low phase shift, a large dynamic range for measurement (up to several kA) while remaining easy to use. The sensors' flexibility makes it easy to clamp the conductor, whatever its type (cable, busbar, strand, etc.) and access conditions.

The design of the click-together opening and closing system means it can be handled with protective gloves.

The AmpFlex® A130 can be connected to the AC voltage input (mV AC, V AC) of any multimeter or measuring instrument equipped with Ø 4 mm female banana plugs.

The AmpFlex® A130 can be powered by batteries or a standard external power supply. If the power supply fails, the instrument's batteries take over. To maximize the battery life, the MiniFlex® A130 has an automatic standby system which can be deactivated at start-up to perform long-term measurement campaigns.

The MiniFlex® A130 has 3 green, yellow and red LEDs indicating, respectively, the power supply status, the status of the automatic standby function and any overruns of the measurement capacity.



## SPECIFICATIONS FOR CURRENT MEASUREMENT <sup>(1)</sup>

Calibre ( $I_N$ )	30 A	300 A	3,000 A
Measurement range in use	0.5 .. 30 A AC	0.5 .. 300 A AC	0.5 .. 3,000 A AC
Specified measurement range	5 .. 30 A AC	5 .. 300 A AC	50 .. 3,000 A AC
Output/input ratio	100 mV / A	10 mV / A	1 mV / A
Bandwidth at -3 dB	10 Hz .. 20 kHz	10 Hz .. 20 kHz	10 Hz .. 20 kHz
Frequency limitation	Null	Null	See curve
Intrinsic uncertainty	≤ 1 % + 4 mV	≤ 1.5 % ( $I < 10 \% I_N$ ) ≤ 1 % ( $I ≥ 10 \% I_N$ )	≤ 1.5 % ( $I < 10 \% I_N$ ) ≤ 1 % ( $I ≥ 10 \% I_N$ )
Phase shift at 50 Hz	≤ 1° (0.5° typical)	≤ 1° (0.5° typical)	≤ 1° (0.5° typical)

## ELECTRICAL SPECIFICATIONS <sup>(1)</sup>

- Operating voltage:**  
1,000 V<sub>RMS</sub> (Cat. IV)
- Battery:**  
Two 1.5 V batteries (NEDA 15A, IEC LR6, AA)  
+5 VDC with a type B micro-USB connector
- Battery life <sup>(2)</sup>:**  
500 hours typical  
3,000 10-minute approx. measurements
- Consumption:**  
10 µA (position OFF)  
90 µA (sleep mode)
- Battery level indication:**  
Flashing green LED (batteries voltage > 2 V)
- Influence of battery voltage:**  
≤ 0.1 % (0.02 % typical) from 3.1 V to 2 V
- Influence of temperature:**  
≤ 0.5 % (0.15 % typical) of output signal per 10 °K
- Influence of relative humidity:**  
≤ 0.5 % (0.2 % typical) of output signal
- Influence of conductor position in the sensor <sup>(3)</sup>:**  
≤ 2.5 % (1 % typical)
- Influence of sensor deformation <sup>(4)</sup>:**  
≤ 1 % (0.2 % typical)
- Influence of adjacent conductor <sup>(5)</sup>:**  
≤  $I_{ADJ} \times 1 \%$  (2 % near click-lock system)  
(0.2 % typical)
- Input impedance of the measuring instrument:**  
≥ 1 MΩ
- Common mode rejection <sup>(6)</sup>:**  
≤ 80 dB (100 dB typical)
- Influence of the measurement instrument's impedance Z:**  
≤ 0.1 % at 10 kΩ

## MECHANICAL SPECIFICATIONS

- **Clamping capacity:**  
Model 80 mm: Ø max 12.5 mm
- **Bending radius:**  
≥ 40 mm
- **Operating temperature:**  
-10 °C to +55 °C
- **Storage temperature:**  
-40 °C to +70 °C
- **Max temperature of measured cable:**  
90 °C for 10 minutes max.
- **Relative humidity for operation:**  
0 to 85 % RH decreasing linearly above 35 °C
- **Operating altitude:**  
0 to 2,000 m
- **Casing protection rating (leakproofing):**  
Casing: IP54  
Flexible sensor: IP 67  
According to IEC 60529 Ed. 2.2-2013

- **Drop test:**  
1 m (IEC 68-2-32)
- **Self-extinguishing capability:**  
Casing: UL94-V2  
Sensor: UL94 V0
- **Dimensions:**  
Casing: 120 x 55 x 39 (overall)  
Connector lead: 3 m (connects sensor to casing)  
Length of output cable: 0.5 m  
Ø of sensor: 12 mm  
Connection cable Ø: 4 mm
- **Weight:**  
1 kg
- **Colours:**  
Sensor: red  
Click-lock system: dark grey  
Casing: dark grey
- **Output:**  
3 coaxial cables with reinforced or double isolation terminated by 1 black isolated male BNC plug

## SAFETY SPECIFICATIONS

- **Electrical safety:**  
Class II equipment with double or reinforced insulation between the primary and the secondary (winding connected to the connection cable) as per EN 61010-1 and 61010-2-032 Ed. 03-2012:  
Sensor:  
- Type B  
- 1,000 V Cat. IV pollution degree 2  
Casing:  
- 600 V Cat. III between the terminals and the external enclosure of the casing
- **Electromagnetic compatibility (EMC):**  
Complies with the industrial environments according to EN 61326-1 Ed. 02-2012:  
- Immunity to radiated fields: at 3 V/m, error ≤ 5 % of measurement range (criterion A)

- (1) Conditions of reference: 23 °C ± 5 °K, 20 % to 75 % RH  
Battery voltage 3.2 V ± 0.1 VDC  
Frequency and form of signal measured: 30 to 440 Hz sinusoidal  
Continuous magnetic field < 40 A/m  
Absence of external AC magnetic field  
Absence of external electrical field  
Measured conductor centred in the circular sensor (coil) after operation for 1 minute  
Measurement instrument input impedance ≥ 1 MΩ
- (2) With 3,000 mA/h batteries, for a supplied voltage between 3.2 V and 1.8 V (1.6 V to 0.9 V per battery), giving an average voltage of 2.8 V
- (3) Whatever the conductor's position within the loop, as long as the sensor is not distorted (circular sensor)
- (4) Oblong shape
- (5) Adjacent conductor carrying an AC current  $I_{adj}$ , in contact with the sensor
- (6) For a 600 V voltage applied between the enclosure and the secondary
- (7) Delivered with a set of 3 female BNC/ Ø 4 mm isolated male banana adapters with 19 mm spacing and a set of identifiers (12 colours)

### 3,000 A calibre

Limitation of current measured according to frequency

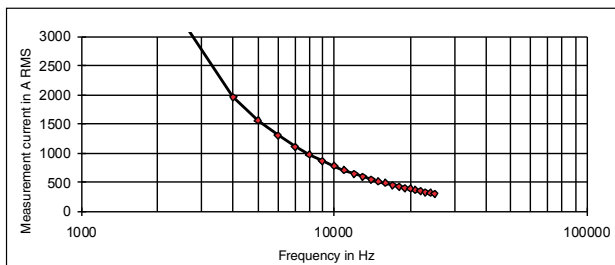

To order	Reference
AmpFlex® A130 30-300-3,000 A / 3 V, length 80 cm Output via 3 coaxial cables terminated by 1 isolated male BNC plug	P01120633

## FREQUENCY RESPONSE

### 30 A calibre

Typical error on measurement according to frequency for a current of 20 A

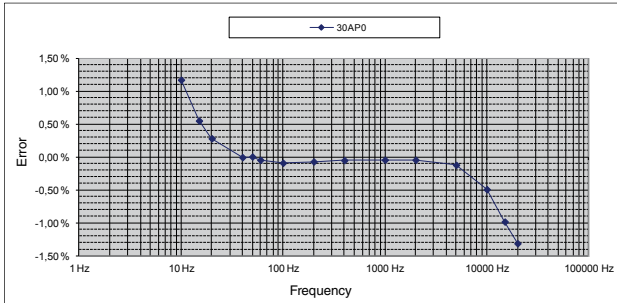

Typical phase shift according to frequency for a current of 20 A

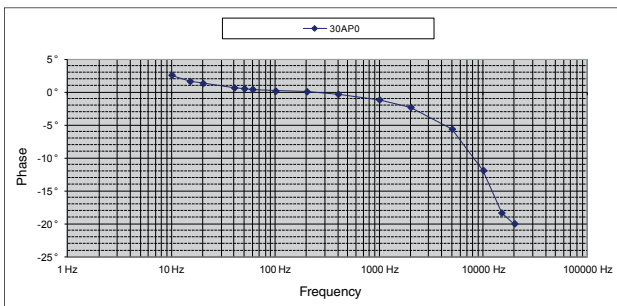

### 300 A calibre

Typical error on measurement according to frequency for a current of 20 A

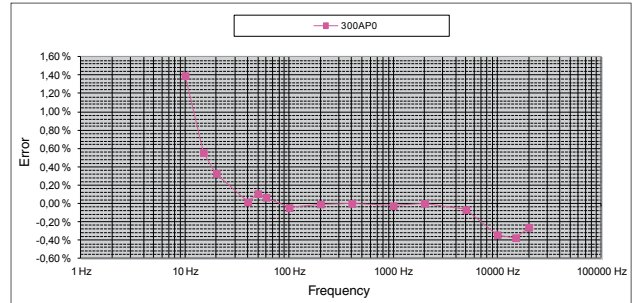

Typical phase shift according to frequency for a current of 20 A

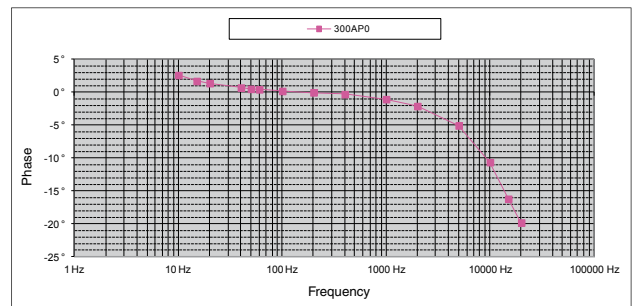

### 3,000 A calibre

Typical error on measurement according to frequency for a current of 20 A

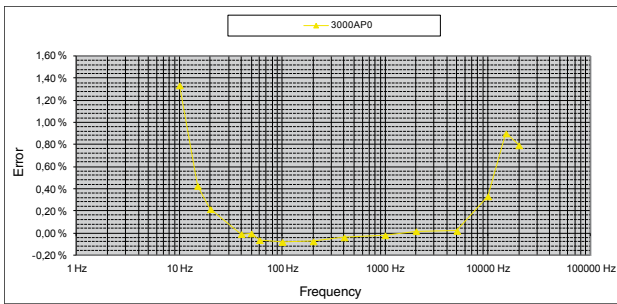

Typical phase shift according to frequency for a current of 20 A

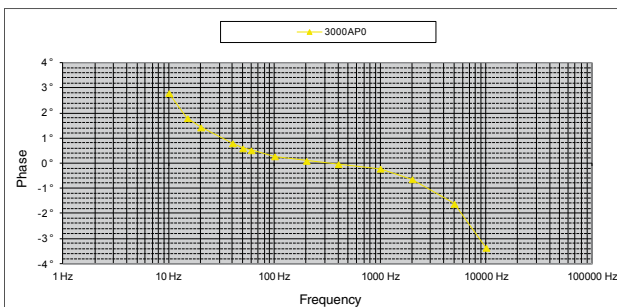

**CONFIGURATIONS**

Level 1

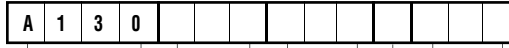

**1 Category**

**2 Lead length in centimeters**

Min value : **050** (50 cm)  
 Max value : **995** (9.95 m)  
 Increment per 5 cm section

**3 Length of connection lead in centimeters**

Min value : **050** (50 cm)  
 Max value : **995** (9.95 m)  
 Increment per 5 cm section

**4 Output via**

- A:** coaxial cable of the length to be defined in **5** terminated by a 600 V CAT III isolated male BNC socket
- B:** cable 50 cm long terminated by 2 red/black Ø 4 mm isolated male banana plugs rated 600 V CAT III
- C:** shielded cable with 2 bared, tin-plated conductors of the length to be defined in **5**, rated 600 V CAT III

**5 Output cable length in cm**

If **4** = "A"

Min value : **050** (50 cm)  
 Max value : **110** (1.10 m)  
 Increment per 5 cm section

If **4** = "C"

Min value : **050** (50 cm)  
 Max value : **995** (9.95 m)  
 Increment per 5 cm section

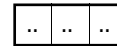
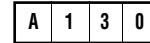

On request - Modulo 5 cm  
 Coding over 3 characters  
 E.g. 50 cm = 050; 9 m = 900

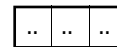

On request - Modulo 5 cm  
 Coding over 3 characters  
 E.g. 50 cm = 050; 9 m = 900

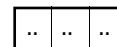

On request - Modulo 5 cm  
 Coding over 3 characters  
 E.g. 50 cm = 050; 1.10 m = 110

Reference: (products available in stock)	Codes
	P01120633

# Deutschlands größter B2B-Onlineshop für Mess- und Prüftechnik.



Mess- und Prüftechnik, Die Experten.

## Ihre Vorteile:

- > Eine unschlagbare Auswahl namhafter Hersteller
- > Hohe Lagerkapazität und kurze Wege
- > Bundesweite Lieferung und schnelle Zustellung meist innerhalb eines Tages
- > Mehrere tausend Mess- und Prüfgeräte
- > Tagesaktuelle Preise und Promotions
- > Warenkorbrabatt bei Online-Bestellung
- > Versandkostenfrei ab € 50,-
- > Dokumenten-Download u. v. m.

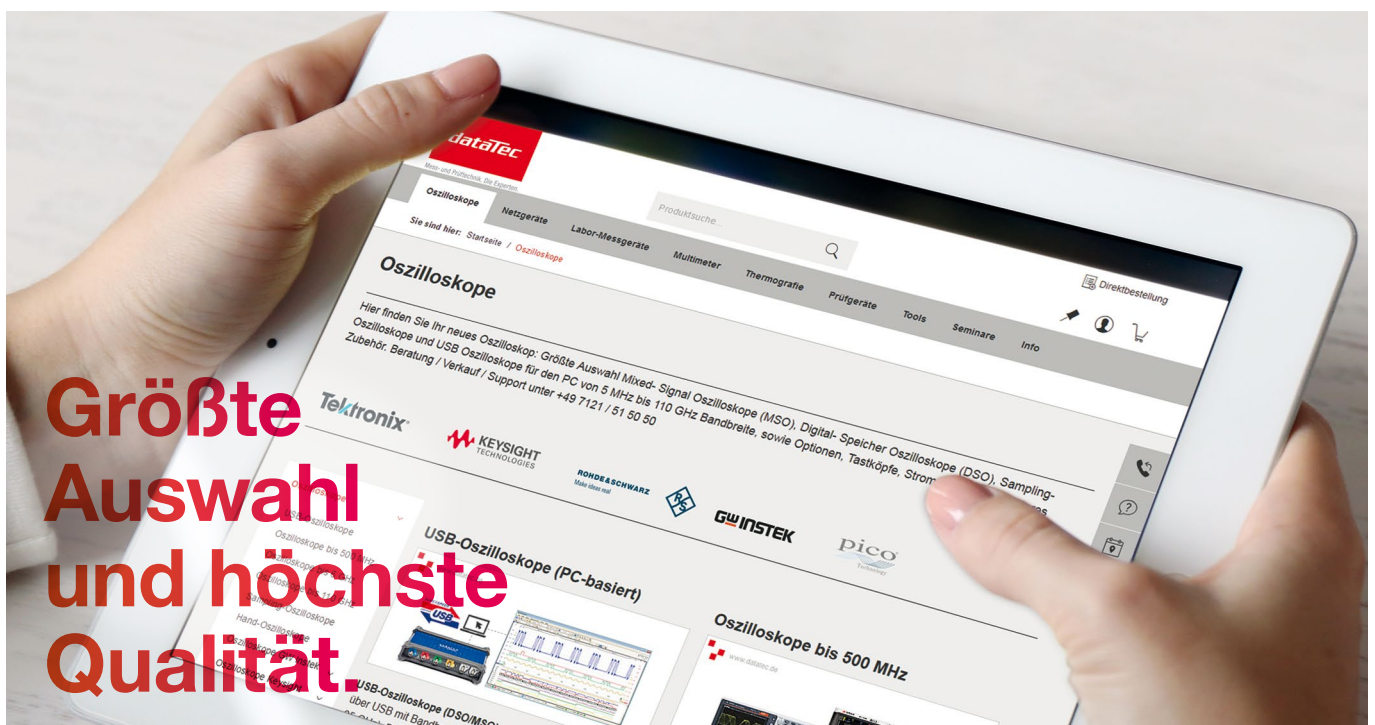

# Wir haben die Lösungen für Ihre Mess- aufgaben.

**dataTec**

Mess- und Prüftechnik, Die Experten.

## Ihre Vorteile:

- > Diplom-Ingenieure, Elektronik- und Elektrotechniker
- > Langjährige Praxiserfahrung und hohe Kompetenz
- > Bundesweit über 20 praxiserfahrene und herstellertestifizierte Vertriebsingenieure im Außendienst bei Ihnen vor Ort

## Experten für:

- > Oszilloskope
- > Spektrum- / Netzwerkanalysatoren
- > Netzgeräte / Stromversorgungen
- > Thermografie / Temperatur
- > Prüfgeräte VDE / Netzanalyse
- > u. v. m.



# Mit unserer Akademie kommen Sie weiter.

**dataTec**

AKADEMIE

## Ihre Vorteile:

- > Wissenstransfer zu sämtlichen Bereichen der Messtechnik, immer auf dem neuesten Stand
- > Vielfältiges Seminarangebot mit renommierten Dozenten, in Theorie und Praxis
- > Modernste Räumlichkeiten mit bester technischer Ausstattung

## Seminarthemen:

- > Prüfgeräte VDE
- > Oszilloskope
- > Labormesstechnik
- > EMV- / HF-Messtechnik u. v. m.

Alle aktuellen Preise und Termine unter:  
>>> [www.datatec.de/akademie](http://www.datatec.de/akademie)

## Technische Seminare und Veranstaltungen.

